

-
-
-
-
-

wattson

Manual for micro-generated electricity

Index

- 3 Introduction
- 4 Typical installation for renewable energy
- 8 Ideal installation for renewable energy
- 12 Activating wattson into renewable mode using holmes
- 14 Viewing the different modes on your wattson
- 16 Viewing the electricity generated in holmes
- 18 Exporting the logged renewable energy data
- 21 Calculations

Introduction

Renewable energy is growing in popularity and has many advantages such as helping reduce your contribution to climate change and avoid using natural resources such as fossil fuels. It is also naturally occurring and won't run out.

wattson can help you measure the amount of power you use as well as the amount of power you generate. With **wattson**'s advanced tilt technology, your used, generated and net power will be displayed on the **wattson** display unit. The data collected by holmes software can then be exported so that the used and generated power can be recorded for logging purposes.

If you have renewable energy such as a wind turbine or photovoltaic cells and you would like to measure the power generated, then in addition to your **wattson**, you will need a second sensor clip which can be purchased separately from your supplier or directly from DIY Kyoto: <http://shop.diykyoto.com/>.



Typical installation for renewable energy

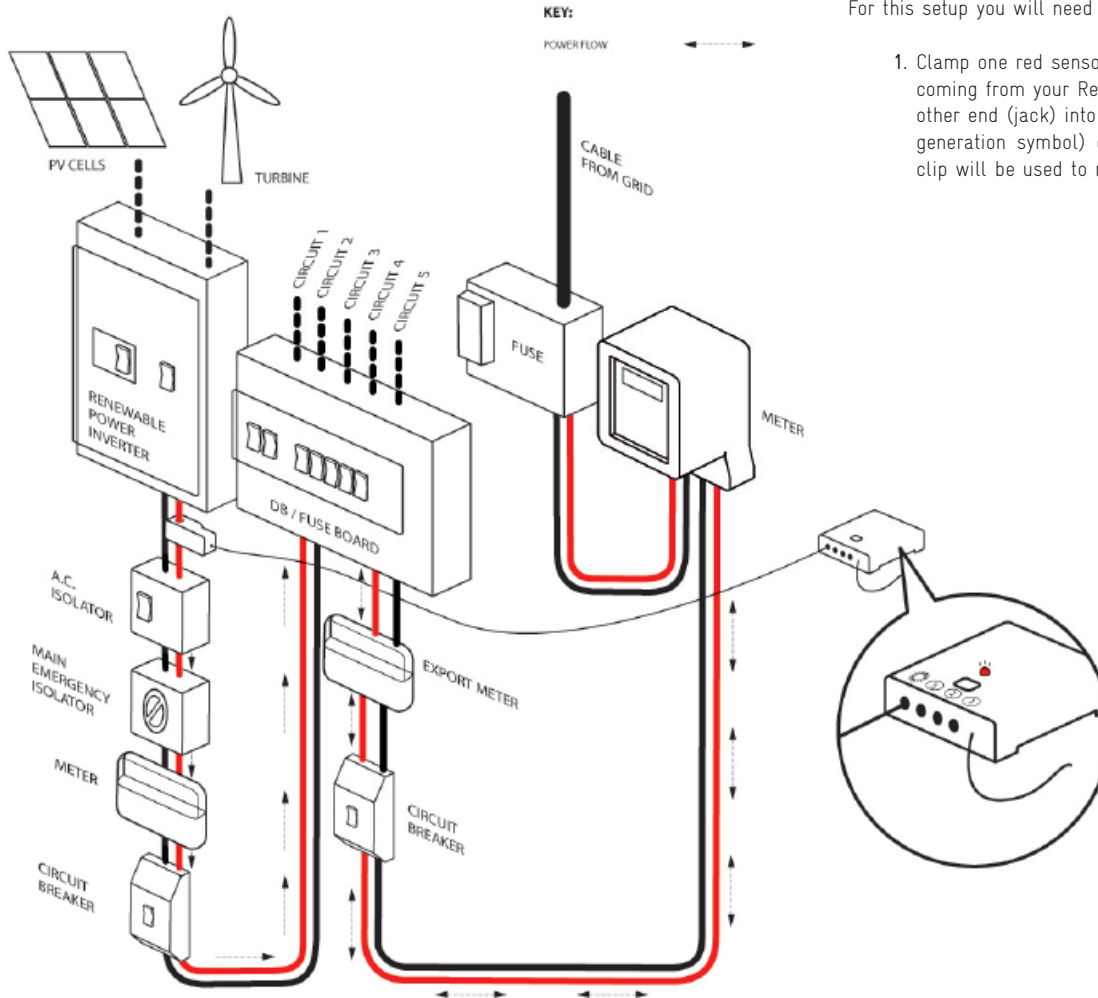

A common renewable energy installation can be seen in the diagram below. For this setup you will need to:

1. Clamp one red sensor clip on the red/live wire that is coming from your Renewable Power Inverter and insert the other end (jack) into socket no.4 (denoted by a micro-generation symbol) on your black transmitter. This red sensor clip will be used to measure the Renewable Power.

- Now clamp the 2nd red sensor clip on either of the red/live wires that exit your electrical meter and insert the other end (jack) into socket no.1. This red sensor clip will be used to measure the Used Power.

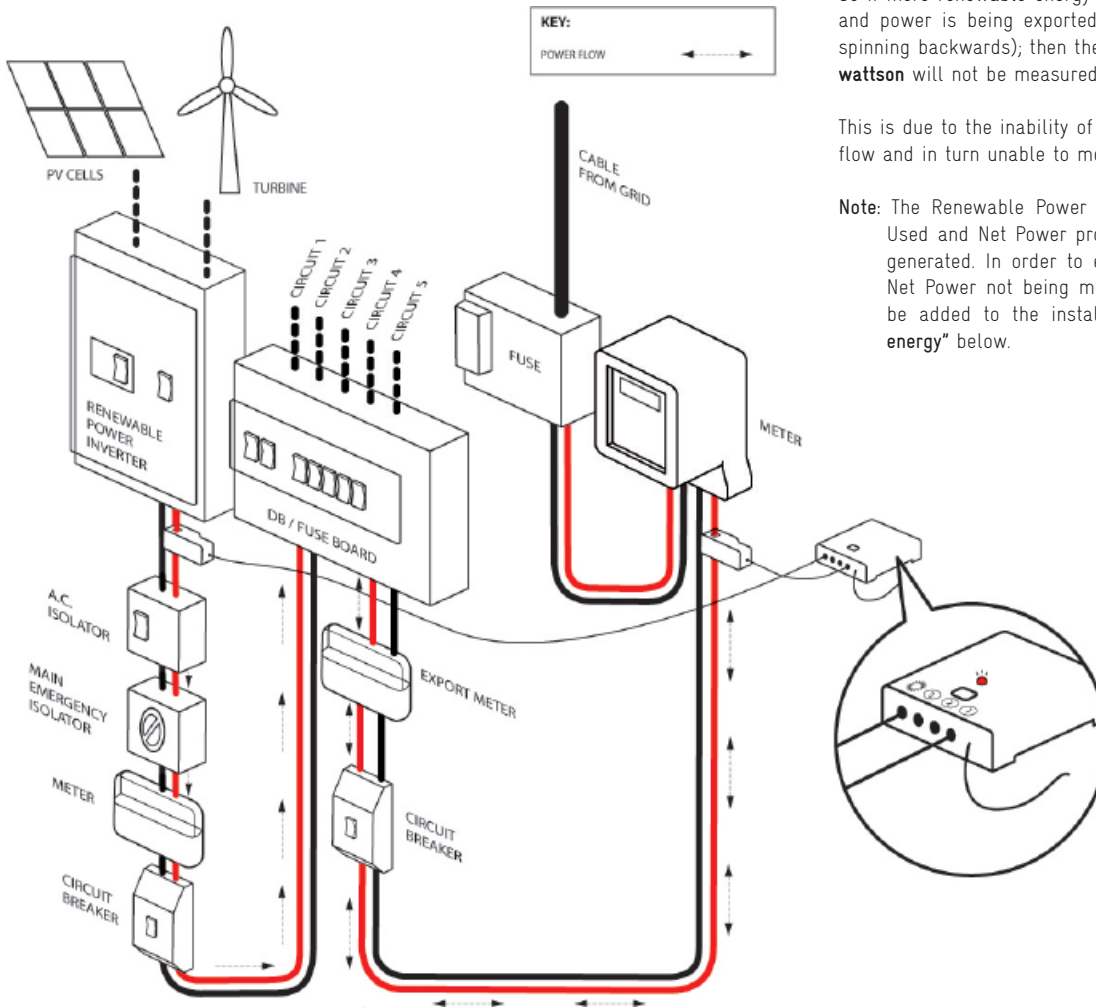

With reference to diagram: The power in the cable between the distribution/fuse board and the meter is capable of flowing in both directions.

So if more renewable energy is being produced than energy is being used and power is being exported back to the grid (denoted by some meters spinning backwards); then the Net Power and Used power displayed on the **wattson** will not be measured correctly.

This is due to the inability of **wattson** to determine the direction of current flow and in turn unable to measure power flowing back to the grid.

Note: The Renewable Power will be measured correctly and so will the Used and Net Power provided more energy is being used than being generated. In order to eliminate the potential problem of Used and Net Power not being measured correctly, a simple junction box can be added to the installation, see "Ideal installation for renewable energy" below.

Ideal installation for renewable energy

This setup is less common but the most cost effective solution if you have the previous setup and at times generate more power than you use. In this setup the cables from the Renewable Power Inverter and the cables from the meter are fed into a Junction Box prior to being fed into the Distribution/ Fuse Board.

Note: The installation of the junction box needs to be fitted by a qualified electrician. For this setup you will need to:

1. Clamp one red sensor clip on the red/live wire that is coming from your Renewable Power Inverter and insert the other end (jack) into socket no.4 (denoted by a micro-generation symbol) on your black transmitter. This red sensor clip will be used to measure the Renewable Power.

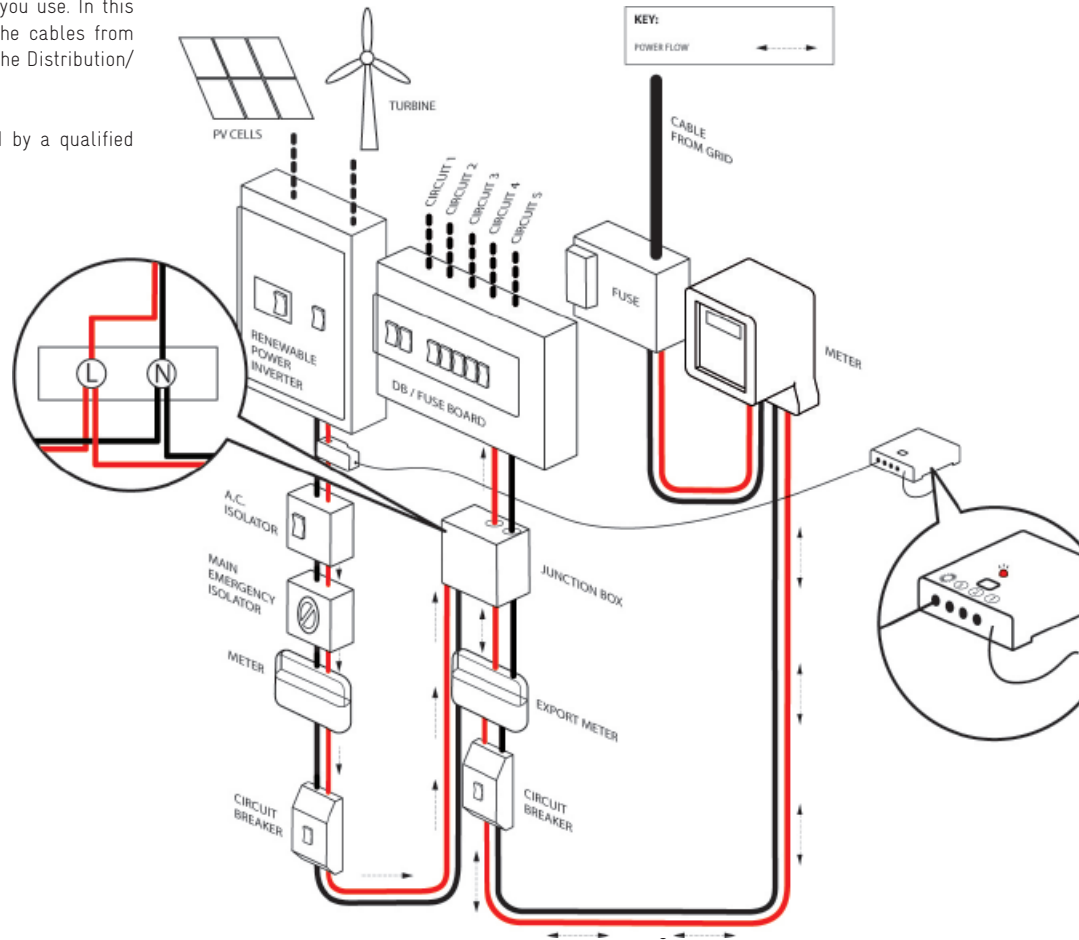

- Clamp the 2nd red sensor clip on the red/live wire that exits your Junction Box and insert the other end (jack) into socket no.1. This red sensor clip will be used to measure the Used Power.

The wiring of the junction box can be seen. By having this Junction Box installed, the power flowing between the Junction Box and the Distribution/Fuse Board will only flow in one direction and therefore make it possible for **wattson** to measure the Used Power and in turn the Net Power correctly.

Note: The Renewable energy, Used Power and Net Power will be measured correctly even if more energy is being generated than being used.

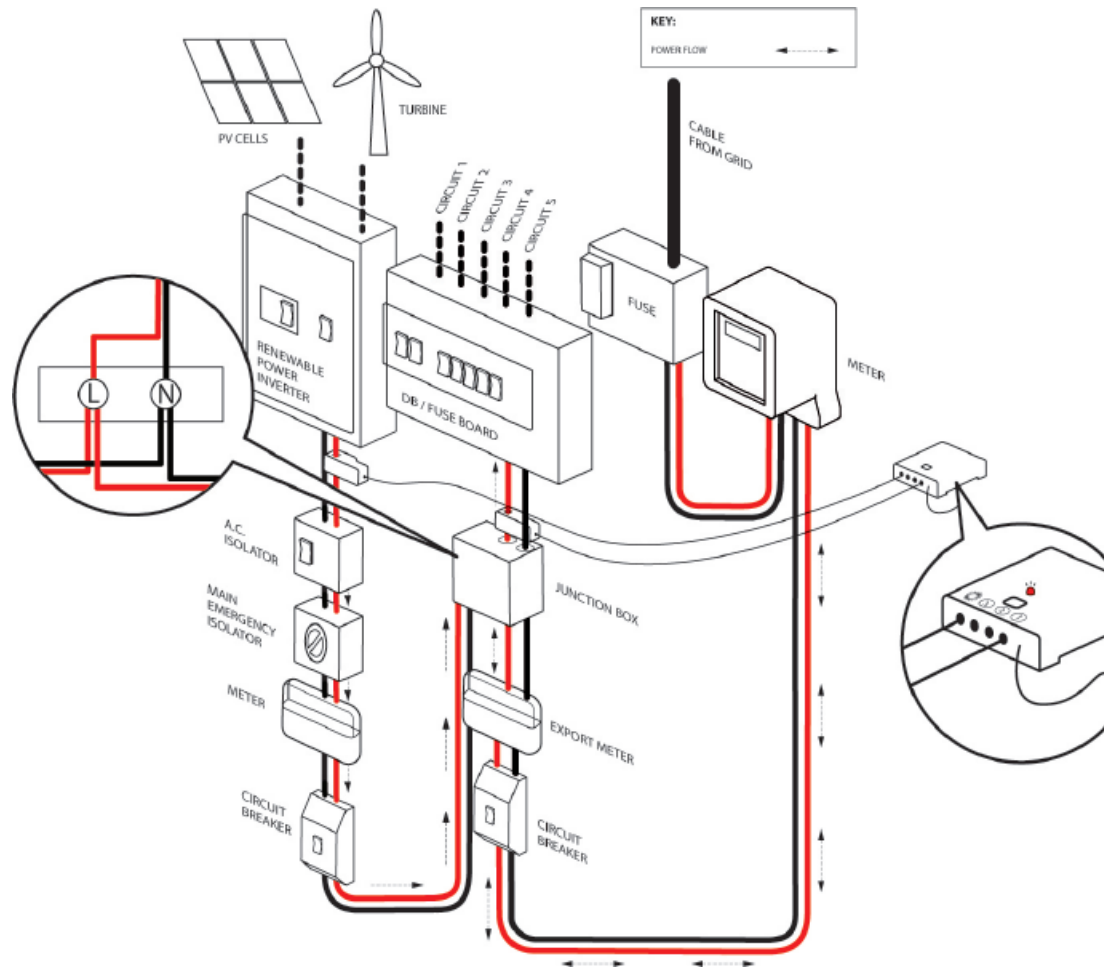

Activating your wattson into renewable mode using holmes

Make sure you have the latest version of holmes (V1.03.1 or later) installed on your PC or MAC. Refer to the holmes manual for instructions on how to download and install holmes.

Connect your **wattson** to your PC or MAC using the supplied USB cable.

1. Start the holmes application
2. Close the automatic pop-up window and then left click on ACCOUNT
3. Left click on OPTIONS
4. Left click in the box next to: "Enable generated logging:"
5. Left click on SAVE & APPLY
6. A pop-up window will appear and then left click on "Yes" to save your preferences.



Viewing the different modes on your wattson

Now that you have enabled generated logging on your **wattson**, your **wattson** will now have 2 additional modes, namely Generated Power and Net Power. **Wattson** has been designed to be positioned on its feet or on the front face.

By repeatedly tilting the **wattson** in a forward motion 60 degrees and then back, the **wattson** will display its various modes respectively, namely:

1. Power In Use
2. Cost
3. Generated Power
4. Net Power

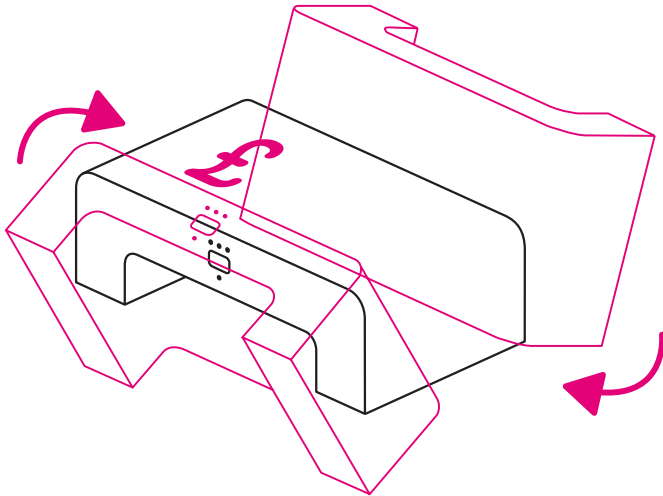

In addition to the various modes on your **wattson**, a softly glowing orange light will be visible on the underside of the **wattson** once more energy is being generated than being used.

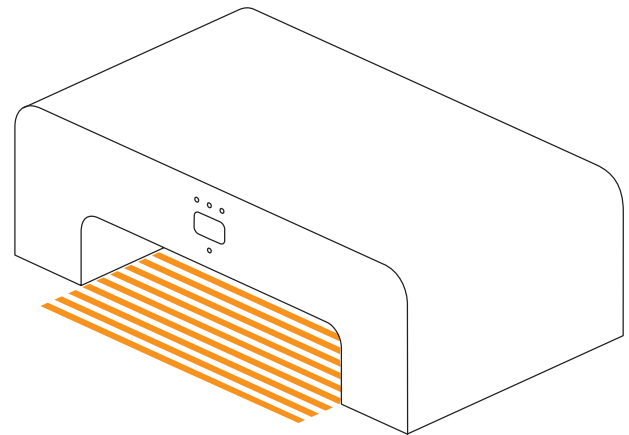

Viewing the electricity generated in holmes

For versions of holmes v1.3.3+ the electricity that you have generated can be displayed in holmes' Energy and Power displays.

If Enable generated logging is set then a renewables switch will appear just above the graph. When switched on (green) then a green line will appear on the graph showing how much electricity you have generated. If no green line appears then no data has been logged for that period.

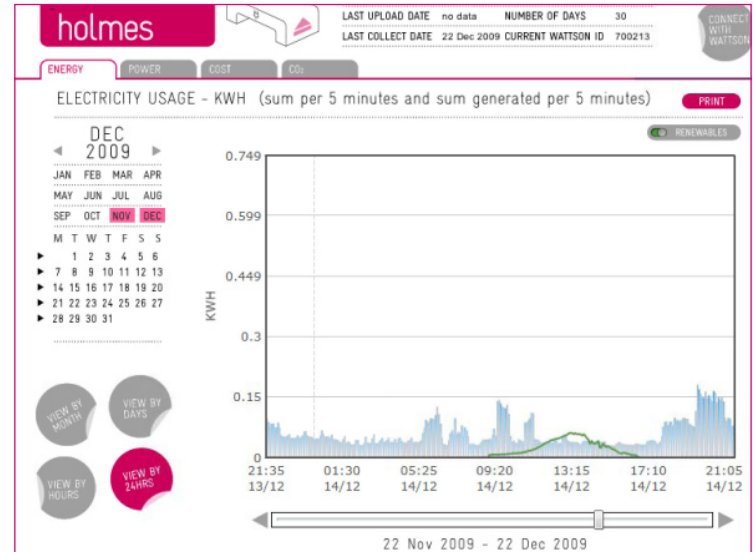

Exporting the logged renewable energy data

Once your **wattson** has been collecting data for more than 24hrs, you will be able to export the renewable energy data that your **wattson** has collected. In order to view the data, you will need to:

1. Start the holmes application
2. Close the automatic pop-up window and then left click on 'ACCOUNT'
3. Left click on 'DATA'
4. Left click on the tab 'NEXT STEP' next to: '1 / EXPORT READINGS'
5. Select the start and end dates that you would like to export data from
6. Left click on 'SAVE & APPLY'
7. A pop-up window will appear and then left click on 'Yes' to export the readings
8. Select the Folder that you would like to export the readings to
9. Left click on 'OK'

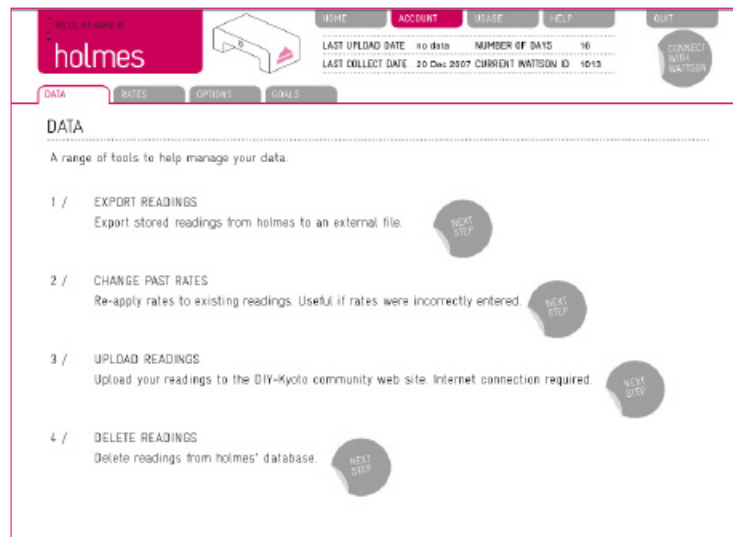

Now that your CSV file has been created, it should look something like this:
export_ID20435_20090519_102111

ID20435 = ID/Serial No. of your **wattson**

20090519 = Date that the extracted file was created

102111 = Random number generated to avoid overwriting

You can open the extracted file with any spreadsheet application capable of viewing CSV files such as Microsoft Excel. To do this:

1. Locate the saved file
2. Right click on the saved file
3. Select 'Open With'
4. Left click on the program that you would like to view the CSV file with
5. Your file should then open with the chosen program

	A	B	C
1	DATETIME	USEDWATTS	GENERATEDWATTS
2	08/02/2009 02:00	1230	247
3	08/02/2009 02:05	1111	247
4	08/02/2009 02:10	832	262
5	08/02/2009 02:15	809	304
6	08/02/2009 02:20	782	220
7	08/02/2009 02:25	897	219
8	08/02/2009 02:30	832	227
9	08/02/2009 02:35	721	258
10	08/02/2009 02:40	717	220
11	08/02/2009 02:45	792	243
12	08/02/2009 02:50	770	244
13	08/02/2009 02:55	831	256
14	08/02/2009 03:00	774	218
15	08/02/2009 03:05	814	322
16	08/02/2009 03:10	1757	334
17	08/02/2009 03:15	877	308
18	08/02/2009 03:20	762	295
19	08/02/2009 03:25	1129	275
20	08/02/2009 03:30	900	232
21	08/02/2009 03:35	661	364
22	08/02/2009 03:40	782	222
23	08/02/2009 03:45	725	223
24	08/02/2009 03:50	730	229
25	08/02/2009 03:55	798	290
26	08/02/2009 04:00	709	238
27	08/02/2009 04:05	1701	327
28	08/02/2009 04:10	2756	230
29	08/02/2009 04:15	2793	255
30	08/02/2009 04:20	2630	220
31	08/02/2009 04:25	754	218

USEDWATTS: This is the average used power over a 5 minute period represented in watts.

GENERATEDWATTS: This is the average power generated over a 5 minute period represented in watts.

Calculations

Using the data in the extracted CSV, you may want to calculate kWh, Cost and Net Power.

TO CALCULATE KWH

Example : If you use 1000W over a 5 minute period

A. Convert power in watts to kilowatts:

$$\text{Power} = 1000 \div 1000 = 1 \text{ kW}$$

B. Convert the minutes to hours:

$$5 \text{ min} = 5 \div 60 = 1/12 \text{ hour}$$

C. Multiply the two numbers together:

$$\text{Electrical energy (kWh)} = 1 \times 1/12 = 0.0833 \text{ kWh}$$

TO CALCULATE COST

Example: If you use 1000W over a 5 minute period and your tariff is 13 p/kWh

A. Multiply the used power (in kW) by the Cost:

$$1 \text{ kW (5 minute period)} * 0.13 \text{ pence} = 0.13$$

B. Convert to hours:

$$0.13 * 1/12$$

$$\text{Cost} = 0.0108\text{£}$$

TO CALCULATE NET POWER

Example: If you use 2500W and you are generating 800W over a 5 minute period

Used Power minus Generated Power

$$2500\text{W} - 800\text{W}$$

$$\text{Net Power} = 1300\text{W}$$

